



CD791R - STEEL MANHOLE COVER

KEY FEATURES

- Integrated lifting handles each tested to 60Kg of direct lift
- Galvanised tray to BS EN 1461:2009



CD791R - Specifications

Product Weight (Kg)	21
Clear Opening	600 x 600
Overall Dimensions	690 x 690 x 96
Cover Material	Mild Steel to EN 10346 2015
Frame Material	Polypropylene (Grade AP9)
Load Rating	10 tonne GPW
Load Rating Data	25kN held for 30 seconds
FACTA Clauses	7.0, 7.2, 7.2.1, 7.2.3
Application	Driveway loading
Locking	None

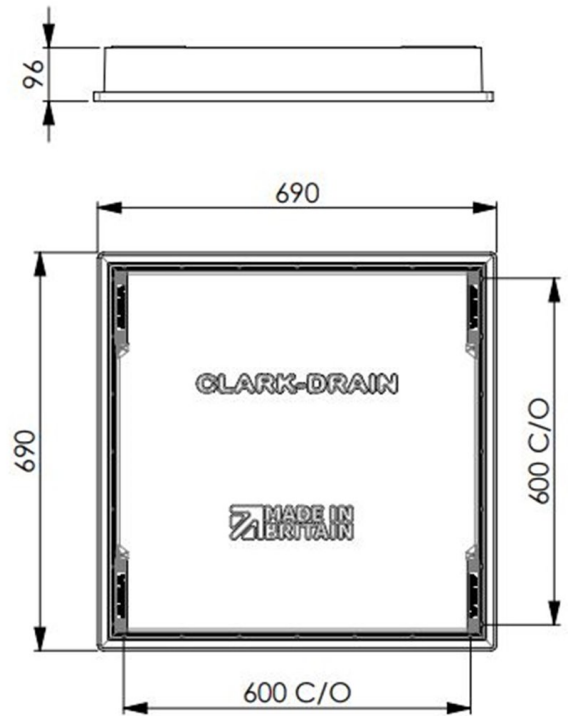

CD791R/V0.1/09-12-2022

Due to our continuous product improvement program features and sizes may be subject to change without notice.

CLARK DRAIN, STATION ROAD, YAXLEY, PETERBOROUGH, PE7 3EQ, TEL. +44 (0) 1733 765317